

Index

The Company

Profile

Facilities

Engineering

Procurement

Equipments

Products

Machinery

Creane

Mixers

Reactors

Turbine Parts

Heavy Steel Structures

Types of Head

Qualifications

Certificates

Contact us



شرکت کارا سازه کیمیا

Kara Sazeh Kimia Co.

— www.karakimia.com —

از گروه صنایع دانش بنیان کارا

The ability of Kara Sazeh Kimia Co. in production of oil & steel equipment & machinery industry

01 Taking advantage of specialized managers & experts in oil & steel field



05 Benefiting from unique and strategic flexibility, according to the conditions



02 Using advanced hardware & software facilities



06 More than two decades of experience involved in EPC



03 Taking advantage of extensive study, research and educational resources



07 Having contractor certificates & rating in petrochemical and refinery fields



04 Using the infrastructures appropriate to all activities related of the product from raw materials to delivery of final product



08 Having valid qualified certificates of integrated management system, ability to design, engineering, procurement, construction, installation & operation



توانمندی شرکت کارا سازه کیمیا در تولید تجهیزات نفتی و فولادی و صنعت ماشین سازی

- بهره گیری از مدیران و کارشناسان متخصص و متعهد در قالب دو گروه نفتی و فولادی
- بکارگیری تجهیزات و امکانات سخت افزاری و نرم افزاری پیشرفته
- بهره گیری از منابع مطالعاتی، تحقیقاتی و آموزشی گسترده
- بهره گیری از زیرساخت های متناسب با کلیه فعالیت های مرتبط با جریان محصول از مواد اولیه تا تحویل محصول نهایی
- بهره مندی از انعطاف پذیری منحصر به فرد و استراتژیک، متناسب با شرایط
- بیش از دو دهه تجربه مشارکت در طراحی، تامین و ساخت
- دارای رتبه و گواهینامه های پیمانکاری در حوزه های پتروشیمی و پالایشگاهی
- دارای گواهینامه های معتبر کیفی سیستم مدیریت یکپارچه، توانمندی طراحی، مهندسی، تامین، ساخت، نصب و راه اندازی

020



Kara Sazeh Kimia
(Volume II)

1



Volume I

**Petrochemical, Refinery
and Power Plant**

2



Volume II

Machine Manufacturing



The Company Profile

KARA Group

“

Kara Sazeh Kimia, as one of the Kara Knowledge Enterprise Industries Group, was established in 2002, the immediate purpose of which was working in the fields of designing, engineering and producing oil, gas, petrochemical, refinery and power plant equipment and so far many different projects with a high desirable quality according to specified requirements set by the customers have been done by this factory.

This factory, having the qualifications and accomplishment like: employing the most modern engineering and designing software, the membership of Markazi province oil, gas, petrochemical and power plant producers community, the membership of producers confirmed by the Iranian national oil company and Pars Gas and Oil Company (P.O.G.C), MOTOR OPERATED (MOP), by the use of modern equipment's is ready and capable to work on different projects.

”

”

شرکت کارا سازه کیمیا یکی از شرکت های زیر گروه صنایع دانش بنیان کارا می باشد که در سال ۱۳۸۲ فعالیت خود را در زمینه طراحی، مهندسی، ساخت و نصب تجهیزات نفت، گاز، پتروشیمی، پالایشگاه، نیروگاهی، کارخانجات و انواع سازه های سبک و سنگین آغاز نمود و تاکنون پروژه های متعددی را با موفقیت و کیفیت مطلوب مطابق با الزامات تعیین شده توسط کارفرما و تحویل به موقع اجرا نموده است.

این شرکت با استقرار سیستم مدیریت کیفیت استاندارد بین المللی ISO9001:2008، با به کارگیری بروز ترین نرم افزار های طراحی و مهندسی، عضویت در انجمن سازندگان تجهیزات و پیمانکاران نفت، گاز، پتروشیمی و نیروگاهی استان مرکزی، عضویت در لیست سازندگان مورد تایید شرکت نفت و گاز پارس (P.O.G.C) و لیست بلند نفت (MOP) و استفاده از تجهیزات پیشرفته و نیروی انسانی متخصص و مجرب، همچنین استقرار سیستم جامع مکانیزه در حوزه های مالی، بازرگانی، برنامه ریزی و مهندسی ساخت آمادگی خود را جهت اجرای پروژه های بزرگ به صورت E.P.C اعلام می دارد.

“



The Company > Facilities > Engineering

دپارتمان تحقیق و توسعه به عنوان مهمترین بخش سازمان کارا سازه کیمیا در خصوص طراحی و ساخت ماشین آلات و تجهیزات صنایع مختلف شناخته می شود. تخصص و توانایی این مجموعه در خصوص بومی سازی ماشین آلات شرکت های مهم فولادی از جمله فولاد مبارکه، فولاد اکسین و فولاد سنگان میباشد که با نرم افزار های Solid Work و Abaqus Ansys مورد تجزیه و تحلیل قرار می گیرد که نسبت به نمونه های خارجی خود کارایی های بهتری را نشان داده است. این واحد در خصوص طراحی ربات های صنعتی و معدنی نیز رزومه قابل قبولی از خود بجای گذاشته است.

The Research and Development department is recognized as the most important section of Kara Sazeh Kimia organization for designing and manufacturing machinery and equipment for various industries. The expertise and capability of this unit in localizing the machinery of major steel companies such as Mobarakeh Steel, Oxin Steel, and Sangan Steel are remarkable, as they are analyzed using software like Solid Work and Abaqus Ansys, showing better efficiency compared to their foreign counterparts. This unit also has a commendable track record in designing industrial and mining robots.

The Company > Facilities

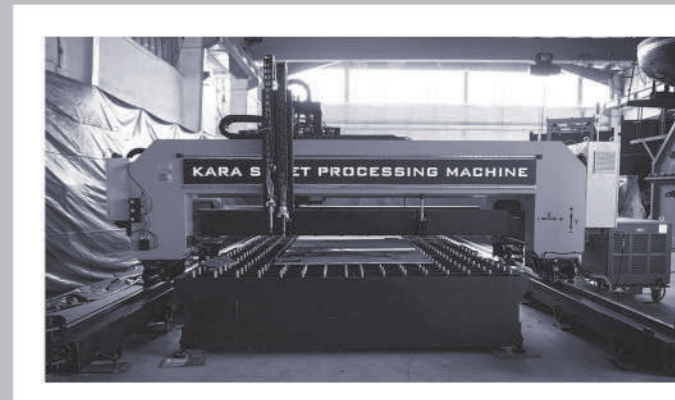
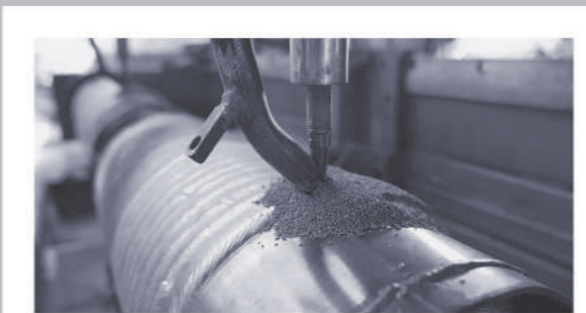
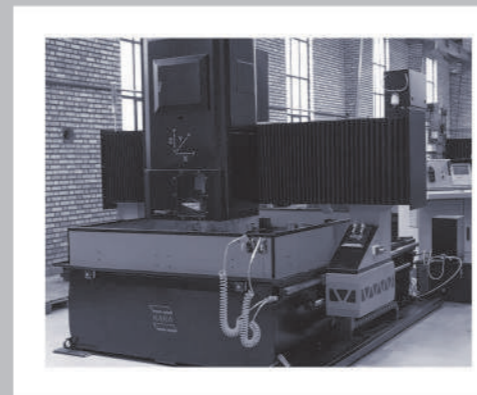

Facilities

- Engineering

- Procurement

Local

Foreign

- Equipments

Construction Workshops Equipments

Mechanical Workshop Equipments

Quality Control Equipments

In order to supply the materials needed for its projects, especially localization projects, this company has imported goods and items that were not domestically produced.

It is worth mentioning that the supply of materials from European countries, China, and the United States of America has been carried out in this company under the conditions of embargo.

In all foreign purchases, the approved suppliers have been identified through the representatives of this company.

Inspection companies such as TUV, IGS, 2R have been responsible approval and issuance of certificates related to this company's clients for all foreign purchases.

این شرکت جهت تامین متریال مورد نیاز پروژه های خود به خصوص پروژه های بومی سازی اقدام به واردات کالاها و اقلامی که تولید داخلی نداشته نموده است.

شایان ذکر است تامین متریال از کشور های اروپایی، چین، ایالات متحده آمریکا در شرایط تحریم در این شرکت صورت پذیرفته است.

در تمامی خرید های خارجی شناسایی تامین کنندگان مورد تایید از طریق نمایندگان این شرکت صورت پذیرفته است.

شرکتهای بازرسی مانند TUV, IGS, 2R تایید و صدور گواهی های مربوط به کارفرمایان این شرکت را در کلیه خرید های خارجی به عهده داشته اند.



Some material suppliers



FACILITIES >

Equipments > Construction Workshops Equipments

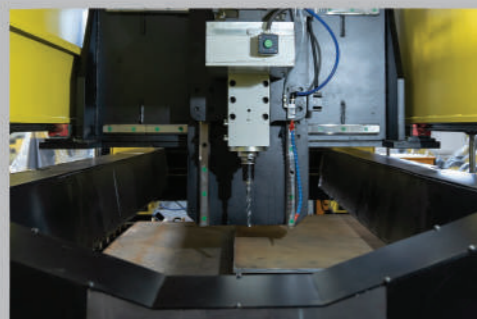

Carousel machine Ø2500*H1220 (mm)	1
CNC carousel machine Ø4000 * H2500 (mm)	1
Horizontal lathes @100*L3000 (mm)	1
T500 Horizontal lathes 0200*L500 (mm)	1
T300 Horizontal lathes 0300*L1400 (mm)	2
Horizontal lathes 8250*L000 (mm)	2
Horizontal lathes 0250*L1500 (mm)	1
CNC lathes	4
Lathes disk L700*W700*H200 (mm)	2
Boring 160 L2000*W1800*H1800 (mm)	1
NC Boring 800*800 (mm)	1
Universal milling machine Heckert T315	1
Milling Machine L6000*W1200*H400 (mm)	2
Gantry Milling Machine L6000*W1200*H1900 (mm)	1
Hub Machine R35 (mm)	1
T500 Turning forehead machine & 1117 (mm)	1
Radial drilling machine 065*H210 (mm)	1
Radial drilling machine 0100*H3000 (mm)	1
Column drilling machine 050*H200 (mm)	1
Table top drilling machine 050*H200 (mm)	7
Magnetic drilling machine 530*H200 (mm)	3

FACILITIES > Equipments



KARA Dishing press machine 1200 Ton & Ø6000 (mm)	1
KARA Dishing press machine 1200 Ton & Ø6000 (mm)	1
KARA Flanging machine thk.36 & Ø6000(mm)	1
Fumace Heat Treatment (1000°c) & (4000*5000*6000) (mm)	1
4 Roll Plate Bending Machine thk. 35*W2500 (mm)	1
3 Roll Plate Bending Machin thk. 15*W2500 (mm)	1
KARA angel roll	1
Welding positioner 5 Ton & 10 Ton	3
Rolling beds 20 Ton & 40 Ton & 100 Ton	20
Mechanical press 12 Ton & 60 Ton & 100 Ton	3
CNC cutting L12000*W2500 (mm)	2
CNC cutting L10000*W3500 (mm)	1
Automatic portable flame cutting machine	18
KARA pipe cutting machine	2
KARA circle cutting machine	2
Plasma cutting pL150	3
Pipe beveling	1
Welding rectifier 800, 630, 400 A	30
Automatic submerge arc welding rectifier 800 A	2

Co2 MIG/MAG welding machine	40
Argon TIG welding machine	2
KARA LGH 1250	2
Automatic submerge arc welding Boom & Column	2
CNC Cladding	1
Spot welding machine	1
Plate guillotine cutter thickness 20*W3000 (mm)	1
Plate guillotine cutter thickness 25*W2000 (mm)	1
Press brake thickness 20*W6000 (mm)	1
CNC press brake thickness 8*W3000 (mm)	1
CNC punching machine thickness 3*L3000*W1000 (mm)	1
Bending machine thickness 1.5*W2000 (mm)	1
Bending machine thickness 3*W2000 (mm)	1
Overhead Crane 25 Ton	3
Overhead Crane 12 Ton	2
Overhead Crane 5 Ton	1
Gantry Crane 10 Ton	2
Sandblast equipments	full set
Painting equipments	full set

Construction Workshops Equipments



Laser Meter	متر لیزری
Digital level gage	تراز دیجیتال
Theodolite camera	دوربین تئودولیت
UT Equipment (Analogue and Digital)	دستگاه التراسونیک (آنالوگ و دیجیتال)
MT Equipment yoke and UV Light	یوک MT و لامپ UV
Sclerometer	دستگاه سختی سنج
Thickness gauge	دستگاه ضخامت سنج
Coating Thickness gauge	ضخامت سنج رنگ
Cross cut tester	تست Cross Cut
Wet gauge tester	تست رطوبت سنج
Hydrostatic testing equipment	تجهیزات تست هیدرواستاتیک
Protractor	انواع زاویه سنج
Micrometer	انواع میکرومتر
Caliper	انواع کولیس
Pressure gauge	انواع گیج فشار
Laser thermometer	انواع ساعت اندیکاتور
Dial indicator	ترمومتر لیزری

QC Equipment

تجهیزات کنترل کیفیت



Products

1. Machinery
2. Creane
3. Mixers
4. Reactors
5. Turbine Parts
6. Heavy Steel Structures
7. Types of Head



CCM Mold Oscillator Machine

Main Products: Machinery

Client: Esfahan's Mobarakeh Steel Complex (MSC)

Accomplished Date: 2022

Quantity: 2 set

Weight: 72 ton (36 ton per set)

Part: Body, Hydraulic Driver & Suspensions



Segment of CCM 6 to 11

Main Products: Machinery

Client: Esfahan's Mobarakeh Steel Complex (MSC)

Accomplished Date: 2024

Quantity: 16 set

Weight: 672 ton (42 ton per set)

Part: Body Frame, Idler & Driver Roller Packages, Hydraulic & Cooling Streams

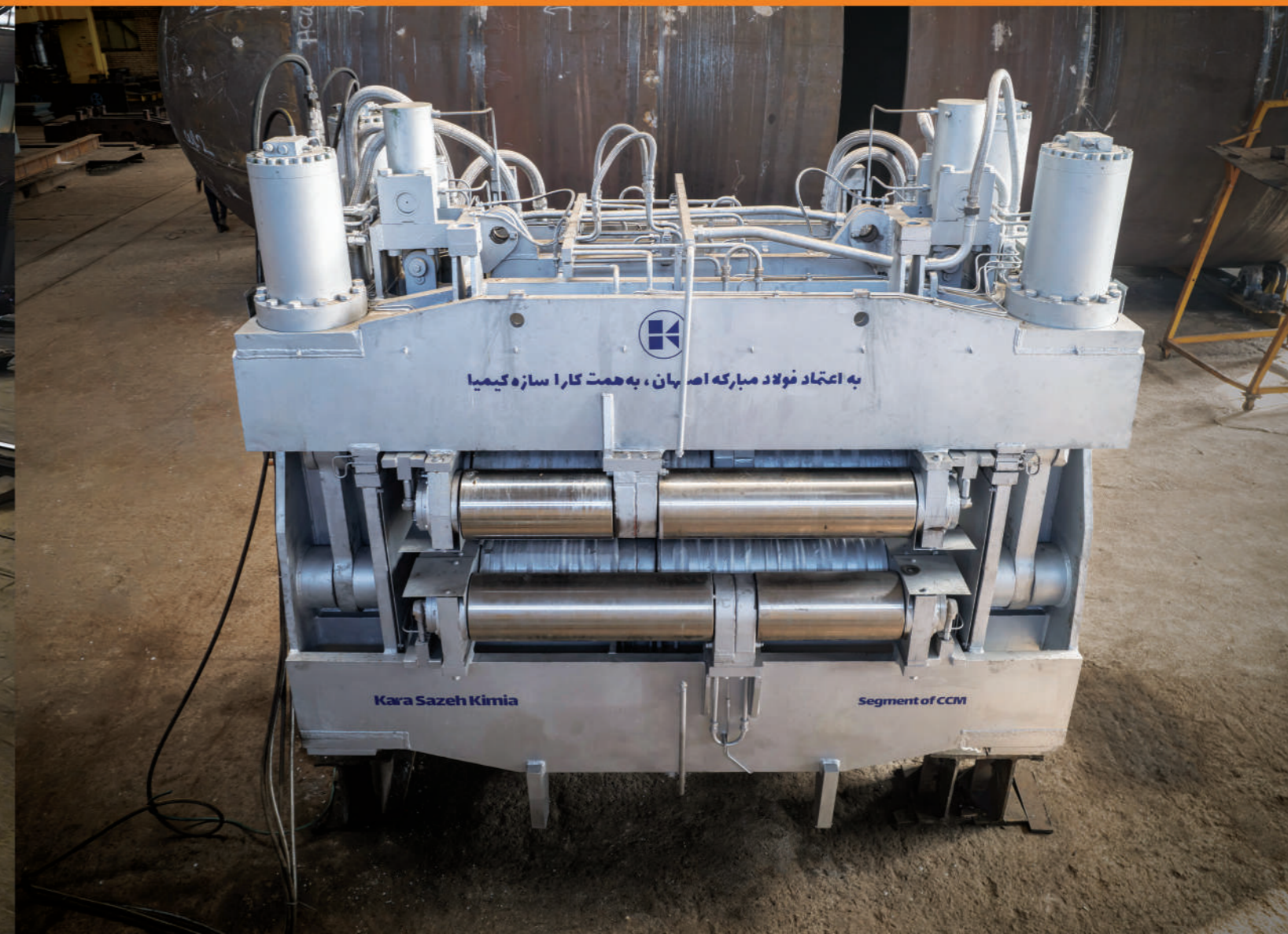

Bowman Machine (CCM)

Main Products: Machinery

Client: Esfahan's Mobarakeh Steel Complex (MSC)

Accomplished Date: 2023

Quantity: 1 set

Weight: 1/5 ton



Hot Cutting Machine

Main Products: Machinery

Client: Saba Foolad Co. (SFC)

Accomplished Date: 2023

Quantity: 1 set

Weight: 3 ton



Rotating Trolley (40 ton)

Main Products: Machinery

Client: Esfahan's Zob Ahan Company

Accomplished Date: 2024

Quantity: 2 set

Weight: 80 ton

Parts: Trolley, Upper Rotation, Rail & Cabin

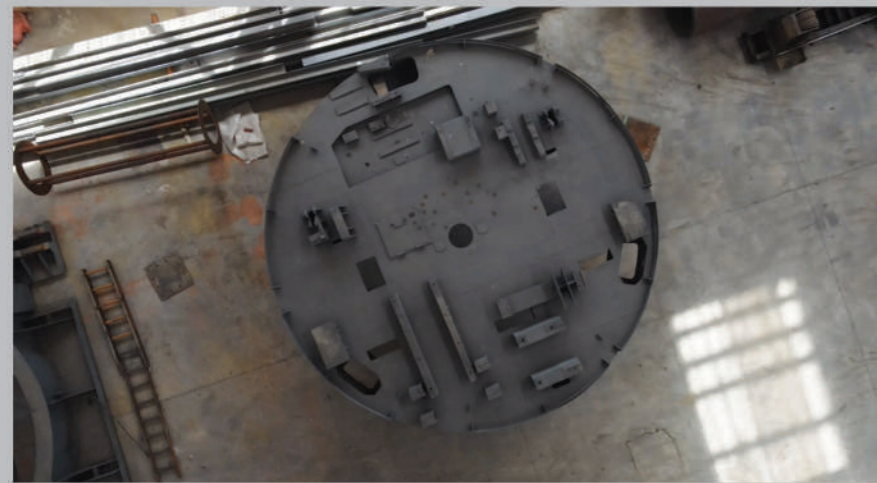

AG Mill Liner Handler Machine

Main Products: Machinery

Client: Sangan Steel Mining Industries Company

Accomplished Date: 2024

Quantity: 1 set

Weight: 30 ton

Parts: Turn Key Solution



Liner Handler

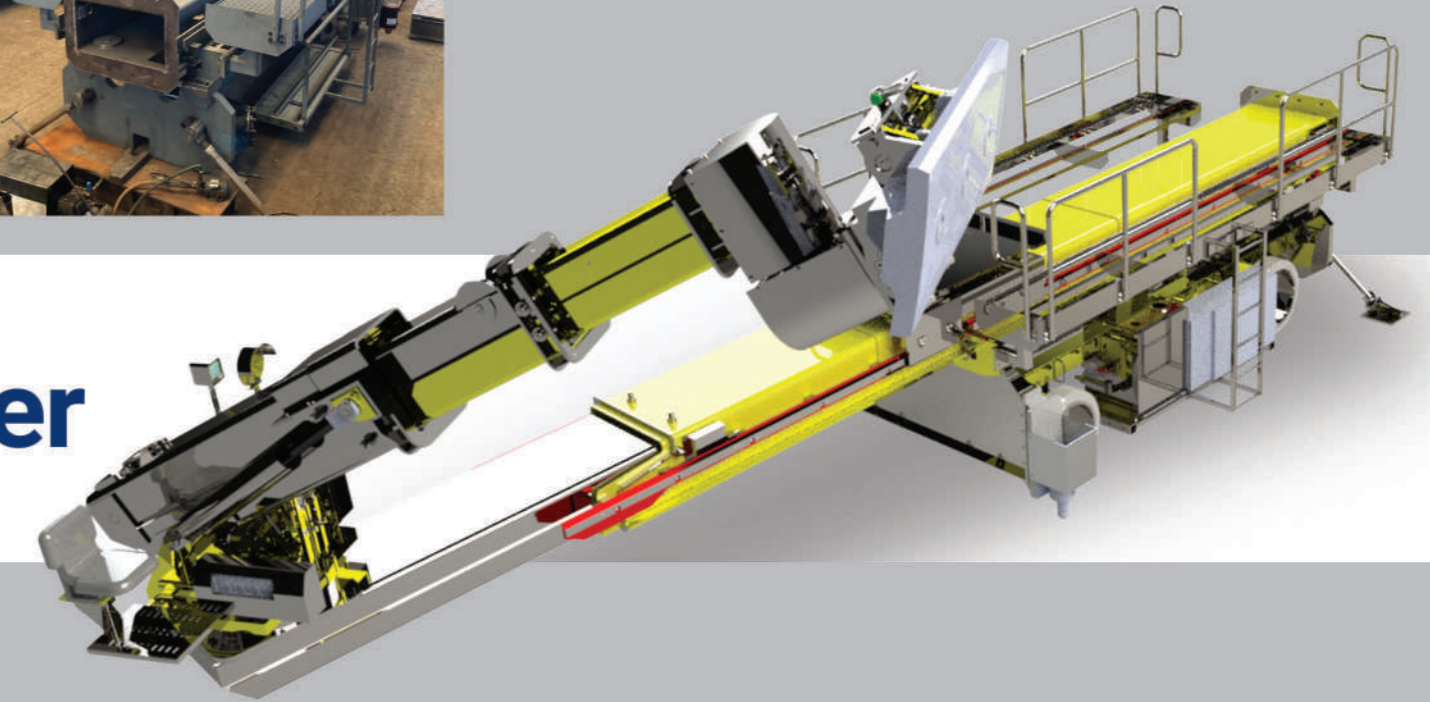

Piler Machine

Main Products: Machinery

Client: Esfahan's Mobarakeh Steel Complex (MSC)

Accomplished Date: 2024

Weight: 30 ton

Width: 5500 mm

Quantity: 1 set

Length: 16000 mm

Height: 4500 mm

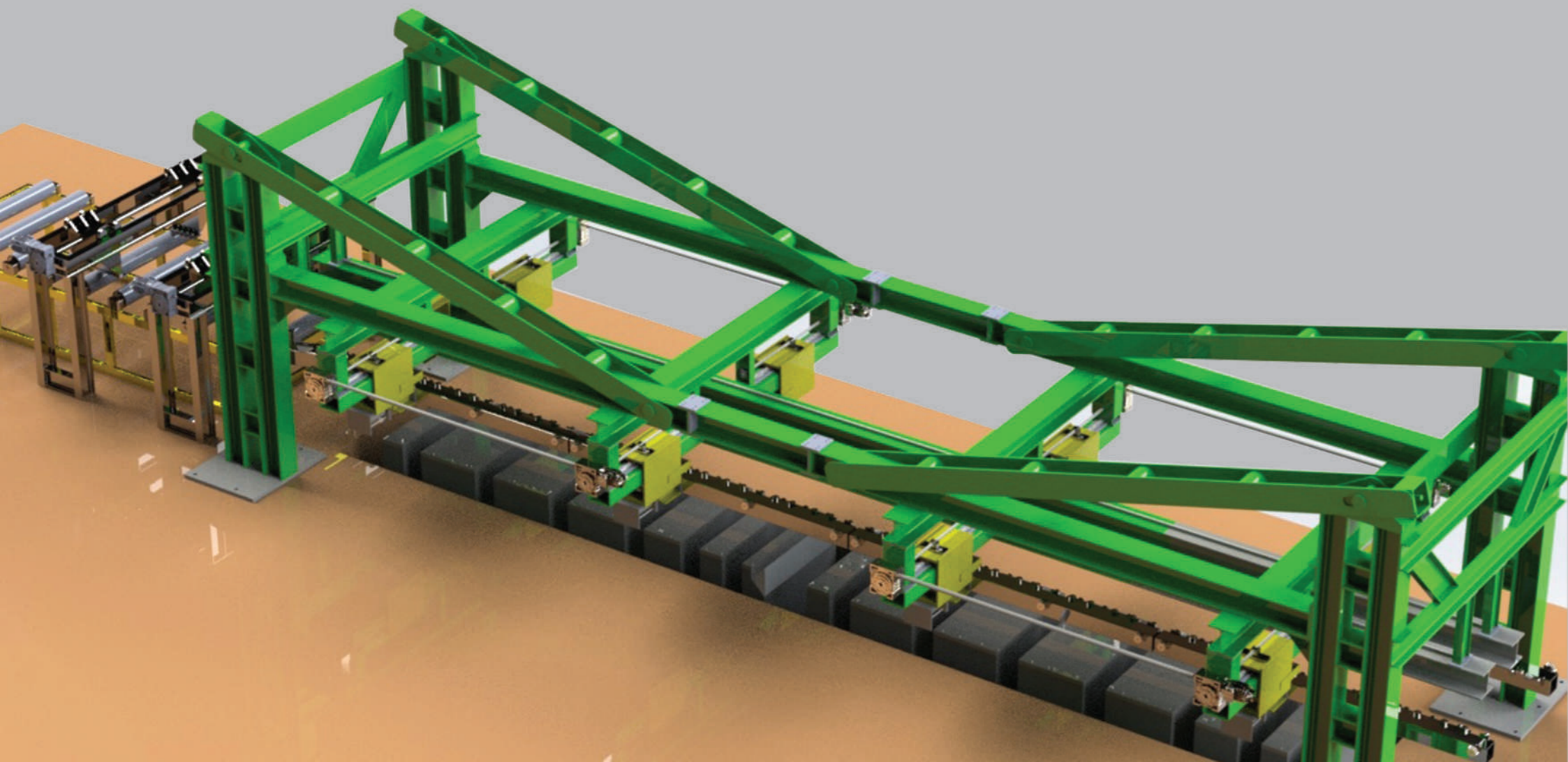

Sheet Turning Machine

Main Products: Machinery

Client: Oxin Steel Co.

Accomplished Date: 2024

Weight: 35 ton

Width: 8000 mm

Quantity: 1 set

Length: 14000 mm

Height: 2000 mm

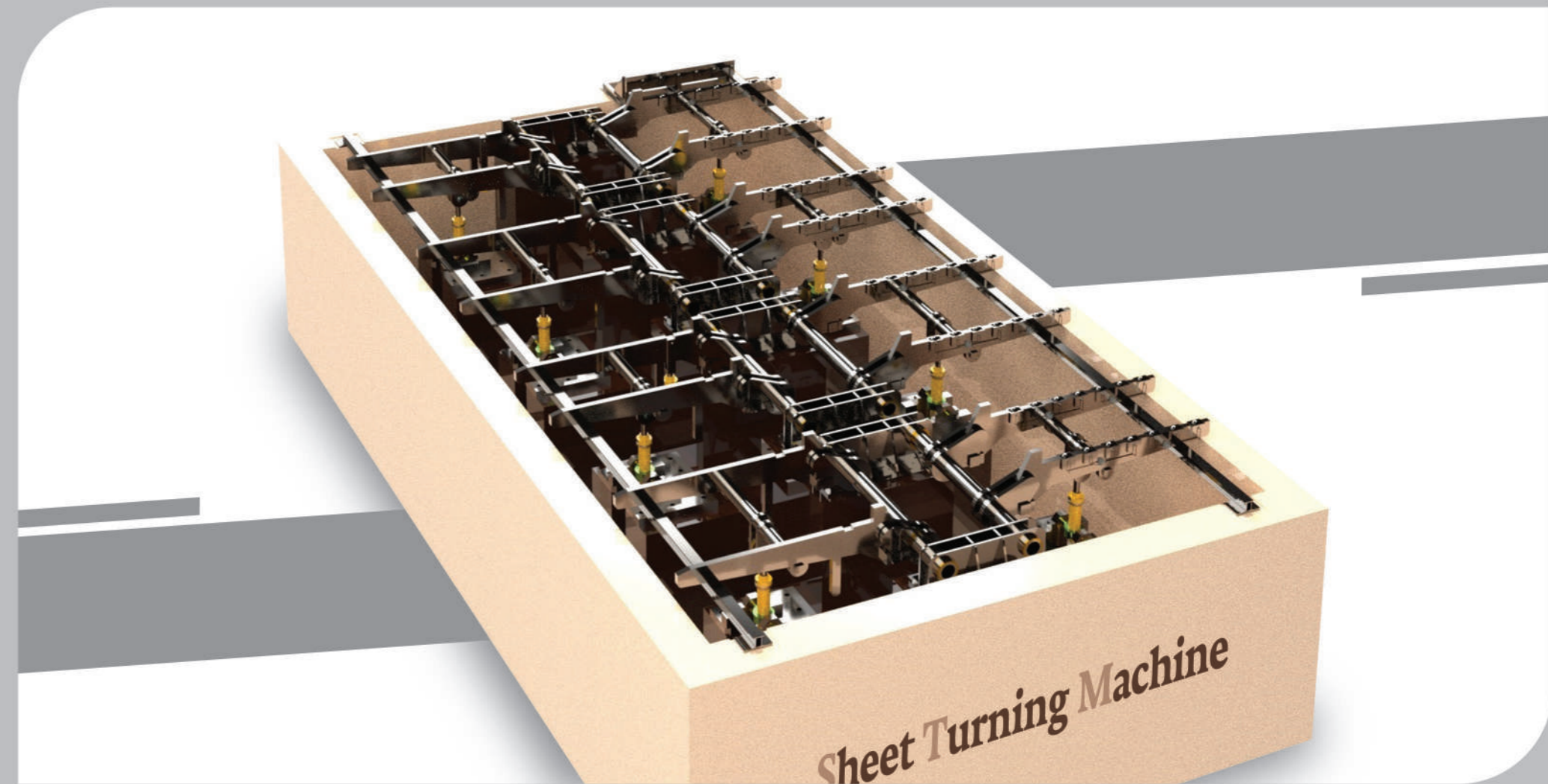

Bundle Cut 2000

Main Products: Machinery

Client: Persian Gulf Star Oil Company

Accomplished Date: 2020

Weight: 5 ton

Width: 23000 mm

Quantity: 1 set

Length: 3000 mm

Height: 33000 mm

Preheater

Main Products: Machinery

Client: Esfahan's Zob Ahan Company

Accomplished Date: 2024

Quantity: 3 set

Description: R&D, Engineering, Procurement



Tundish Preheater, Vertical & Horizontal Ladle Preheater

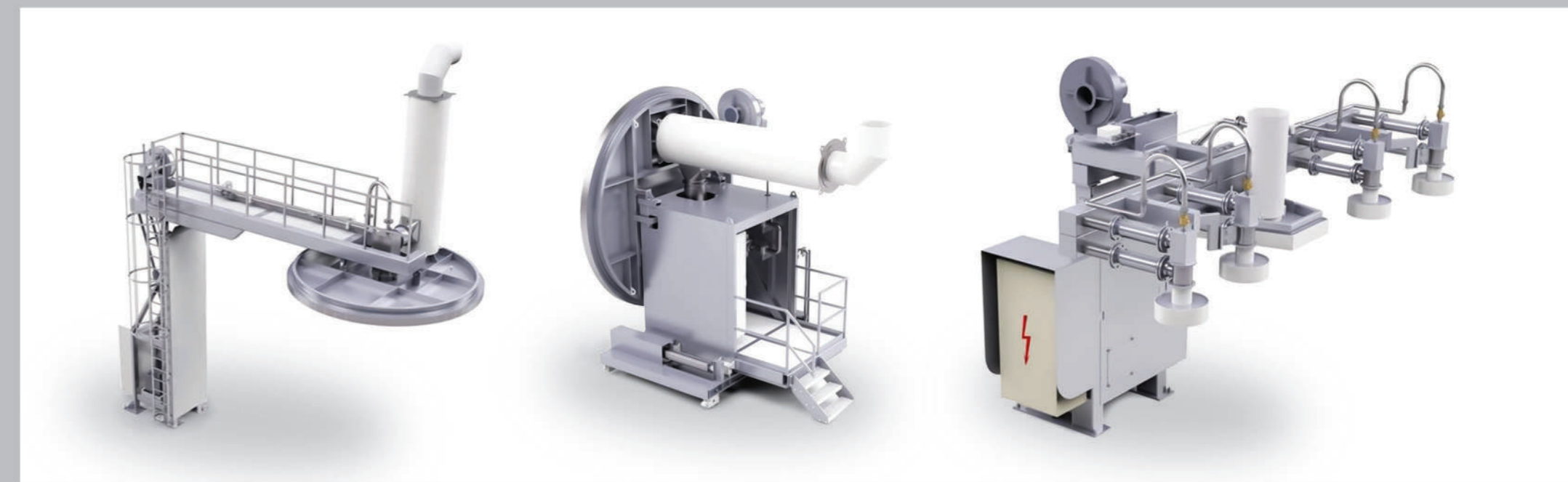

Strip Mill Banding Machine

Main Products: Machinery

Client: Esfahan's Mobarakeh Steel Complex (MSC)

Accomplished Date: 2024

Width: 5400 mm

Automation: CNC

Quantity: 1 set

Length: 5400 mm

Updated Technology: Welded and Tested Banding

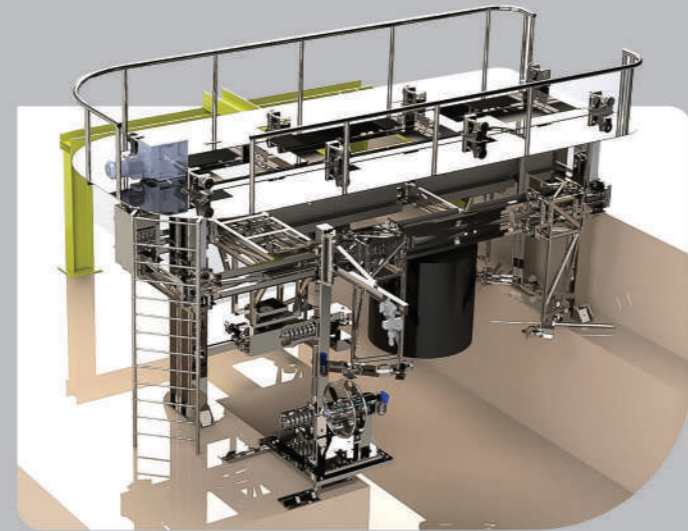
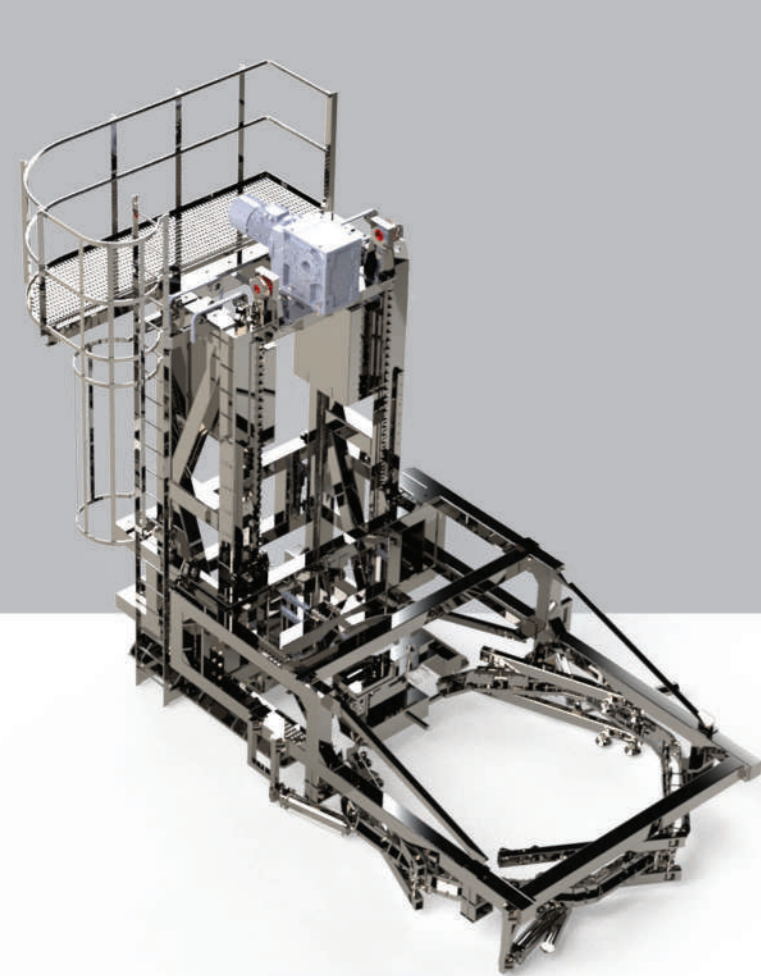

Strip Mill Banding

Vacuum Degassing Chamber

Main Products: Machinery

Client: Sanat Foolad Aliyazhi Esfahan Company (SFAE)

Accomplished Date: 2020

Weight: 60 ton

Quantity: 1 set

Parts: Upper Door, Body Internals

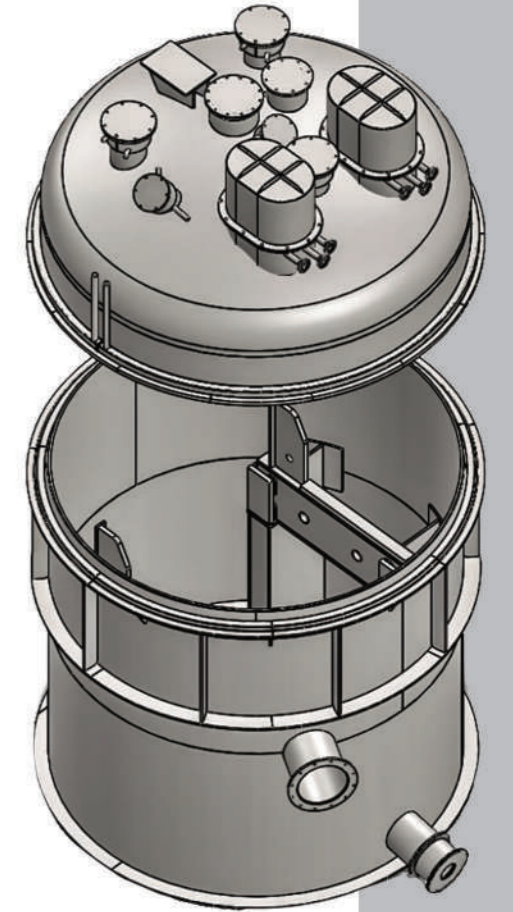

Mixer Cassette

Main Products: Mixers

Client: Hegmatan Sugar Factory

Accomplished Date: 2018

Weight: 50 ton

Diameter: 4400 mm

Quantity: 1 set

Length: 10000 mm

Thickness: 34 mm

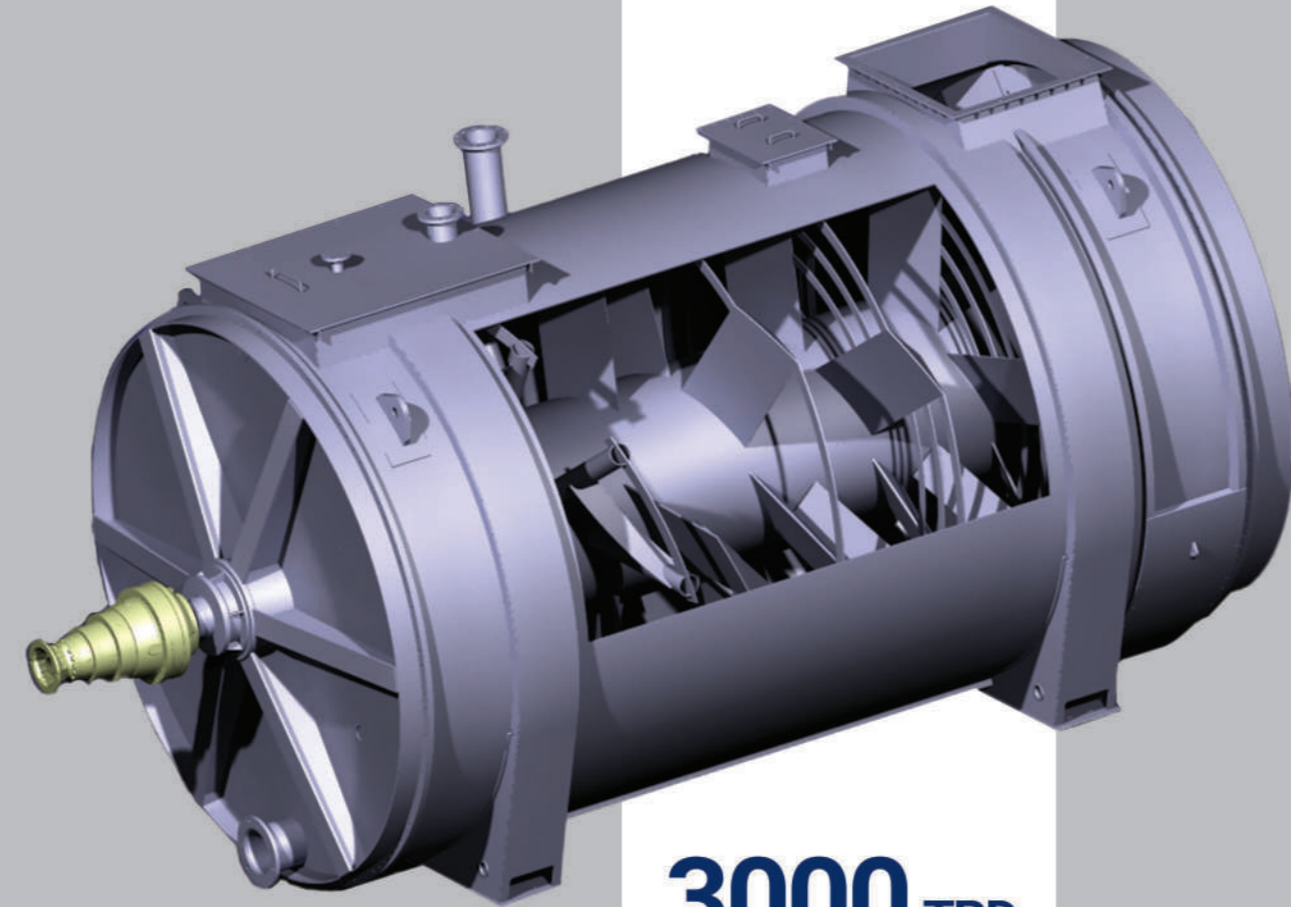

3000 TPD
Mixer Cassette

Gantry Cranes

Main Products: Creane

Client: Iran ShipBuilding & Offshore Industries Complex Co. (ISO ICO)

Accomplished Date: 2015

Weight: 800 ton

Parts: Bogie, Column, Jib System, Lower Part of Gantry, Gantry Girder

Quantity: 4 set

Capacity: 35 ton, 60 ton, 160 ton



OPSIM Ball Mill Body

Main Products: Turbine Parts

Client: Opal Parsian Co.

Accomplished Date: 2021

Weight: 250 ton

OD: 6634 mm

Quantity: 1 set

Length: 10000 mm

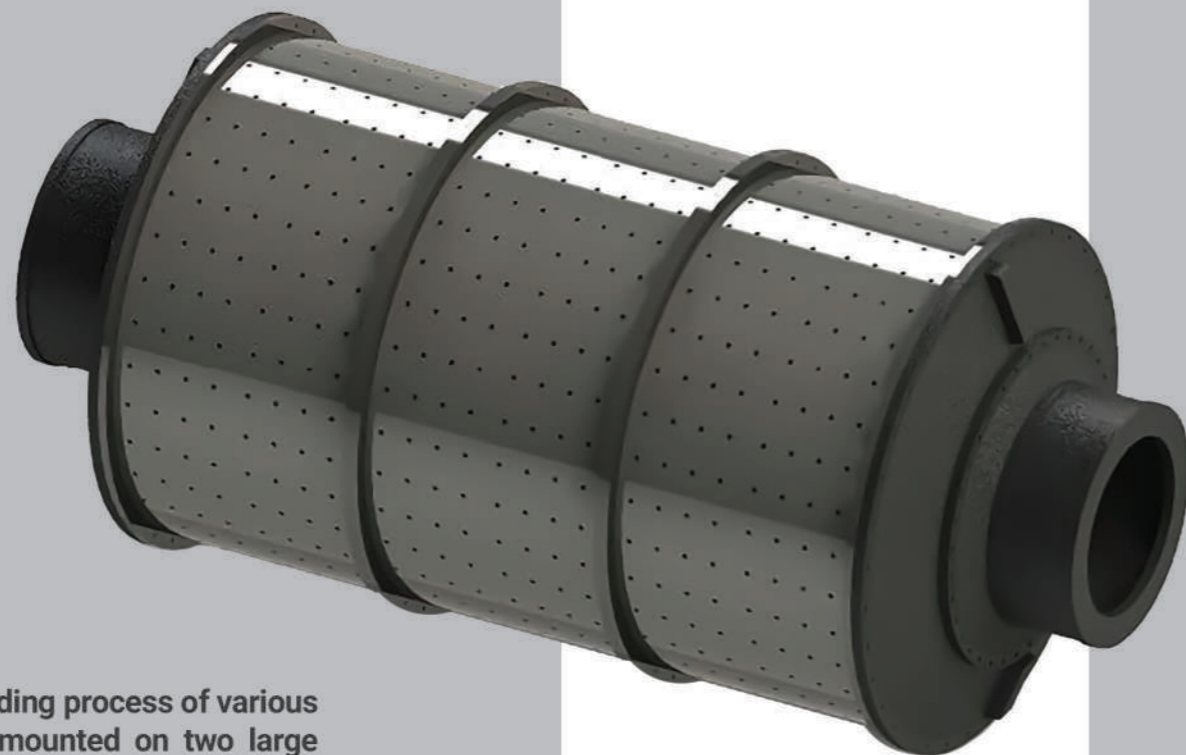
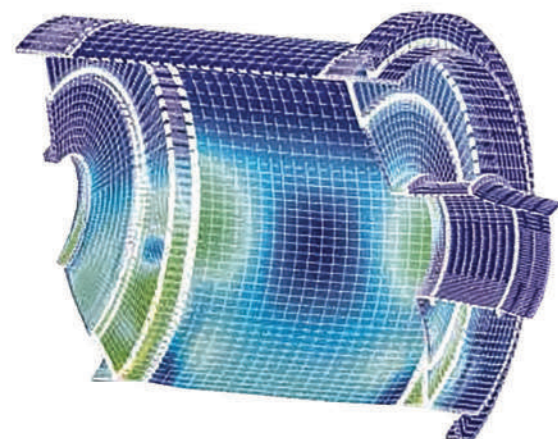

The OPSIM Ball Mill Body is a critical component in the grinding process of various materials. It is designed as a low-speed rotary cylinder mounted on two large bearings horizontally. Inside the cylinder, grinding media such as steel balls are placed. These balls are lifted to a certain height by the action of centrifugal force and friction, and then they fall or drop to grind the material inside the mill.

Oil Reactor With Coil

Main Products: Reactors & Mixers

Client: Sepahan Oil Company (SOC)

Accomplished Date: 2022

Weight: 30 ton

Diameter: 3700 mm

Quantity: 4 set

Length: 5200 mm



REACTORS KSK

Gas Turbine Combustion Chamber

Main Products: Turbine Parts

Client: Mapna Turbine Engineering & Manufacturing Co. (TUGA)

Accomplished Date: 2009

Quantity: 8 set

Weight: 180 ton



Parts :

- Outer Shell
- Adaptor Ring
- Manhole Cover
- Tube Oil pan
- Mixing Chamber
- Frame Flame
- Top Dome



Exhaust Casing

Main Products: Turbine Parts

Client: Middle-East Industrial Gas Turbines (M.I.G.T) Company

Design Cooperator: Siemens Co.

Quantity: 40 set

Accomplished Date: 2012

Weight: 60 ton



Steel Structures

Main Products: Heavy Steel Structures

Client: Sangan Steel Mining Industries Company

Accomplished Date: 2021

Weight: 1600 ton

Length: 167000 mm

Height: 34000 mm

Operating Duration: 4 months

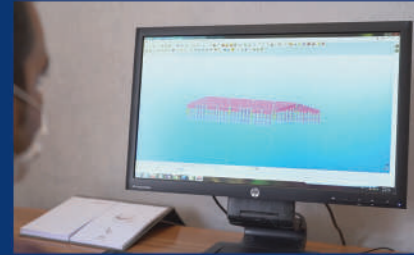

Steel Structures

Main Products: Heavy Steel Structures

Client: Damavand Energy Company

Accomplished Date: 2024

Weight: 1700 ton

Length: 65000 mm

Height: 27000 mm

Operating Duration: 6 months



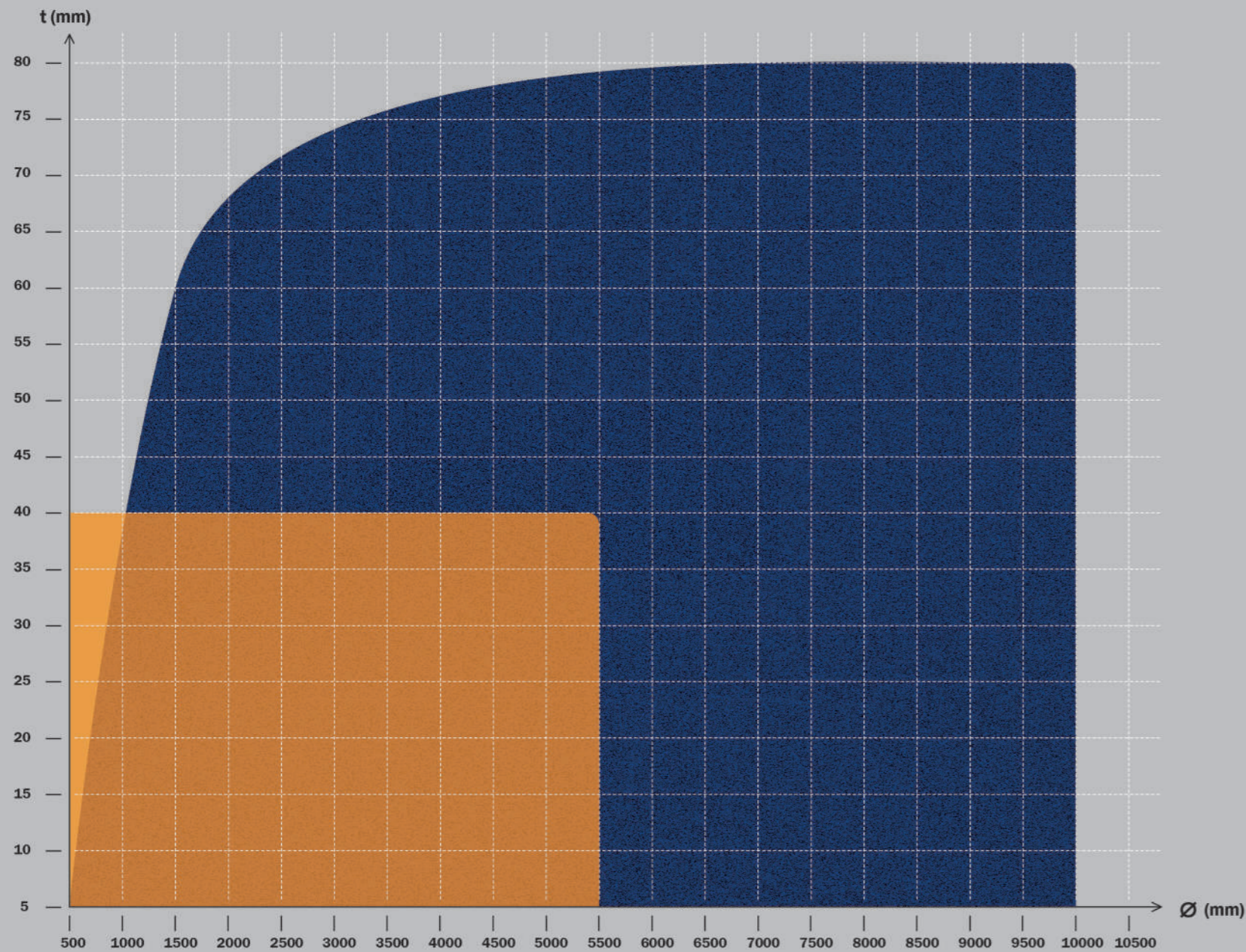

Single Pieces Heads Construction

Multi Pieces Heads Construction

Ø = Outside Diameter , t = Wall Thickness

Products > Types of Head



▶ Heads Construction

One of the main activities of this company is production the heads of pressure vessels and storage tanks by Cold Forming and Spinning in different types such as Elliptical, Hemispherical, Torispherical, Dish and Flat Head.

Head forming Equipment which consists of two 1200-Ton capacity CNC Dishing Presses and Machine Flanging has been launched for the first time in Iran by Kara Company in 2004.

This Equipment has the capability of production of heads from the diameter of 600 mm to 5200 mm and also up to 36 mm in thickness in the case of producing as single piece and even in higher thicknesses in the form of multi pieces.

یکی از فعالیت های اصلی این شرکت ساخت عدسی مخازن تحت فشار و ذخیره به روش سرد و چرخشی است که در انواع مختلف Elliptical, Hemispherical, Torispherical, Flat تولید می گردد.

مجموعه فرمینگ عدسی مشتمل بر دو دستگاه پرس عدسی با ظرفیت ۱۲۰۰ تن و رولینگ عدسی میباشد که برای اولین در کشور توسط شرکت کارا ساخته و از سال ۱۳۸۳ به بهره برداری رسیده است.

در این مجموعه تولید عدسی از قطر ۶۰۰ میلیمتر تا ۵۲۰۰ میلیمتر تا ضخامت ۳۶ میلیمتر به صورت یکپارچه و در ابعاد و ضخامت های بالاتر به صورت تاج و گلبرگ بدون محدودیت در قطر تا ضخامت ۶۰ میلیمتر امکان پذیر می باشد.





Products > Types of Head

Single Pieces Heads Construction



Hemispherical Head



Elliptical Head



Flat Bottomed Head

Certificates



KARA SAZEH KIMIA as a developing and growing company, has always paid attention to the use of proper management systems. In the last years quality management standards such as, OHSAS 18001, ISO 9001, ISO 14001, ISO 45001, ISO 3834 were applied and the new management procedures such as strategic management and self-assessment based on EFQM excel-lence model will be established.



Qualifications

Contact us

Factory: 6th Km of Tehran road, Arak, Iran

Post No.: 38193-84532 Fax: +98 (86) 3413 1420

Tel.: +98 (86) 3413 1210-11 , +98 (86) 3413 1421-22

Tehran Office:

No. 807, Shahab complex, Vali-Asr St., Tehran, Iran

Post No.: 15117-35138 Tell. : +98 (21) 8870 6617-18

کارخانه: اراک، کیلومتر ۶ جاده تهران

کد پستی: ۳۸۱۹۳۸۴۵۳۲ فکس: ۳۴۱۳۴۲۰ (۰۸۶)

تلفن: ۱۱ - ۳۴۱۳۱۲۱۰ (۰۸۶) و ۲۲ - ۳۴۱۳۱۴۲۱ (۰۸۶)

دفتر مرکزی: تهران، خیابان ولیعصر روبروی پمپ بنزین

ساعتی، برج شهاب، واحد ۸۰۷ کد پستی: ۱۵۱۱۷۳۵۱۳۸

تلفن: ۱۸ - ۸۸۷۰۶۶۱۷ (۰۲۱) فکس: ۸۸۷۱۵۵۲۱ (۰۲۱)

E-mail: info@karakimia.com

www.karakimia.com



KARA SAZEH KIMIA

Petrochemical and Refinery Equipment

